



Fox Delta

Amateur Radio Projects & Kits

FD- UPP

Technical Details & Assembly Note: USB PIC Programmer

FD-UPP: USB PIC Programmer:

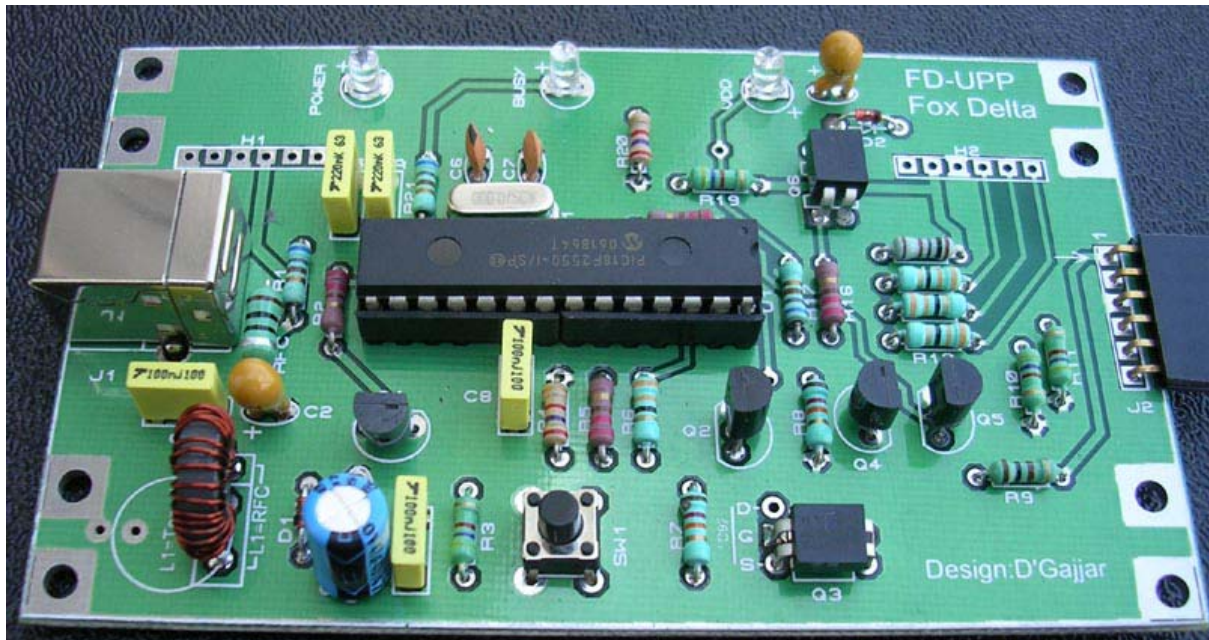

PIC Programmer is an essential tool if you wish to learn or build a project that uses Microchip PIC Micro Processors such as DDS, Repeater Controllers and LCD Power Meter.

This programmer is built around Microchip's PICKIT2 programmer, which is basically a surface mount, fully assembled, ready to use product. It's called a "Kit" but it is not!! This one is a true kit for radio amateurs.

Benefit of making PICKIT based programmer for amateur radio is further supported by freely downloadable PICKIT2 software for windows. Microchip keeps this software updated for new devices that they launch.

In this project, to make it simple, I have removed the voltage level change capability of firmware for VDD 3V. Means, this programmer will only program 5V PIC Micros.

Project uses a PIC16F2550 in 28pin DIP package. All diodes are standard lead type & FETs are either in TO92 or HEXDIP packages, to make assembly smooth & easy.

Kit is supplied with FD-PB1 Programming board. PB1 uses standard IC Sockets for 40, 28, 8,14, 20 & 18PIN DIP PIC Micros.

In view to make a suitable metal case for this programmer, FD-UPP has two headers H1 & H2, which will be used by “piggy back” Programming board I will design later.

Technical information:

This is a Non SMT clone of PICKIT2 with major schematic reshuffle related to use of standard components & FETs.

For complete intro on PICKIT2, documents & PC software, please visit:

http://www.microchip.com/stellent/idcplg?IdcService=SS_GET_PAGE&nodId=1406&dDocName=en023805

Basics of this design:

PIC16F2550, loaded with a Bootloader & firmware, controls VPP/VDD to target board. PIC is running at 20mhz.

Q1, 2, 3 and 5 with L1, D1 & C3 forms a voltage pump for generating VPP voltages for target.

Q4 & 6 controls the VDD.

Programmer gets its working power from USB.

Is this all? Yes, it is!!

Schematic of the Serial Port PIC Programmer:

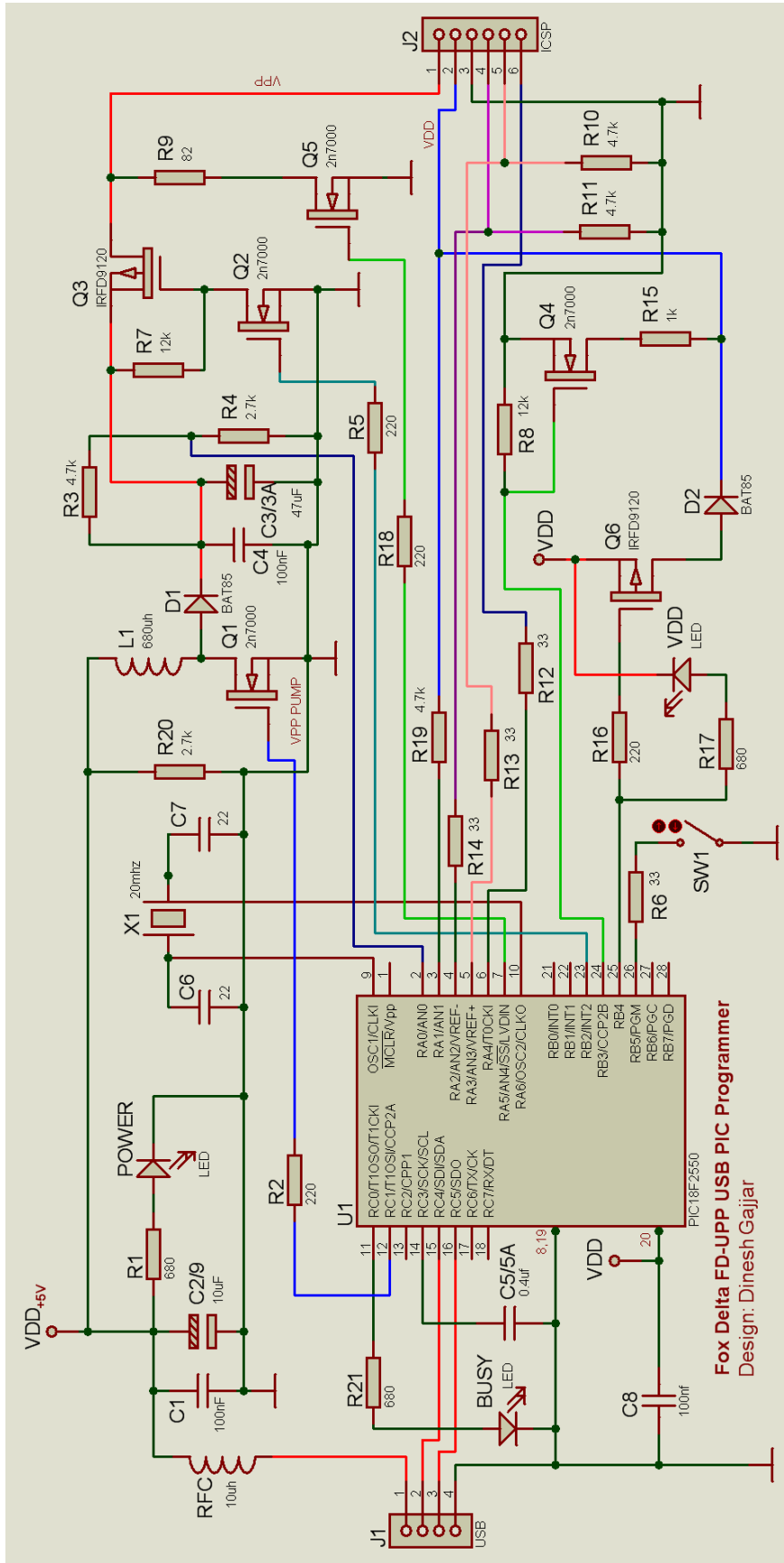

FD-UPP Parts List:

Quantity	Part ID	Description
1	FD-UPP	PTH PCB
1	J1	USB Connector Type B
1	J2	6 Pin R/A Female
1	X1	20MHZ Crystal HC49U/S
1	L1	Toroid+Copper Wire (24 Turns @28AWG, 680uh)
1	U1	PIC16F2550
1	SW1	4mm Push button
3	LED	Red/Green/Yellow
2	Q3, Q6	IRFD9120
4	Q1, 2, 4, 5	2N7000
1	IC Socket	28PIN (14+14)
1	RFC	10uh
Other Parts:		
3	R1, 17, 21	680 ohms
4	R2, 5, 16, 18	220 ohms
4	R6, 12, 13, 14,	33 ohms
1	R9	82 ohms
4	R4, 10.11, 19	4.7K
2	R3, 20	2.7K
1	R15	1K
2	R7, 8	12K
2	C1, 4, 8	0.1uf
2	C5/5A	0.22uf
2	C2, 9	10uf Tan
2	C3	47uf Electro 40V
2	C6, 7	22pf Ceramic
2	D1, 2	BAT85

(C3A not used)

PB1 Parts List:

1	PB1	PCB
1	Socket	40 PIN
1	Socket	28 PIN (14+14)
1	Socket	20 PIN
1	Socket	18 PIN
1	DIP SW	4 Position DIP Switch (LVP)
1	Resistor	10K (LVP)
1	Header	6 PIN Male Header R/A

Silk Snap:

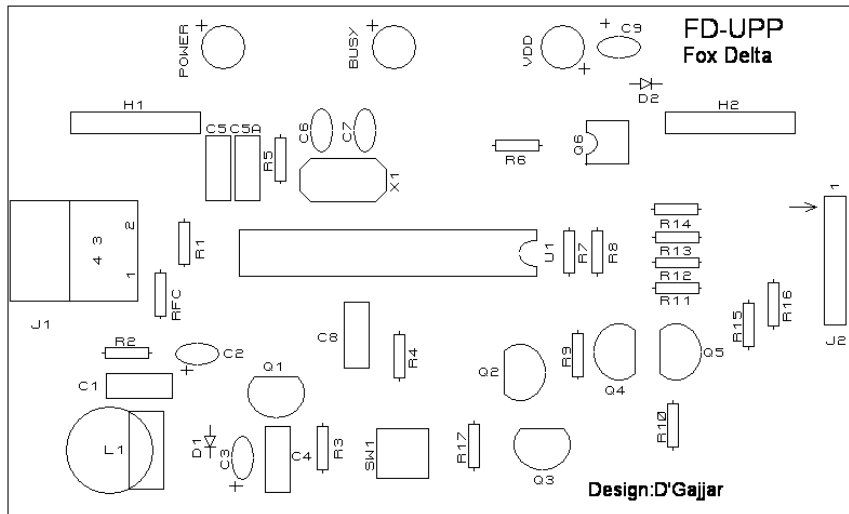

PB1 Programming Board:

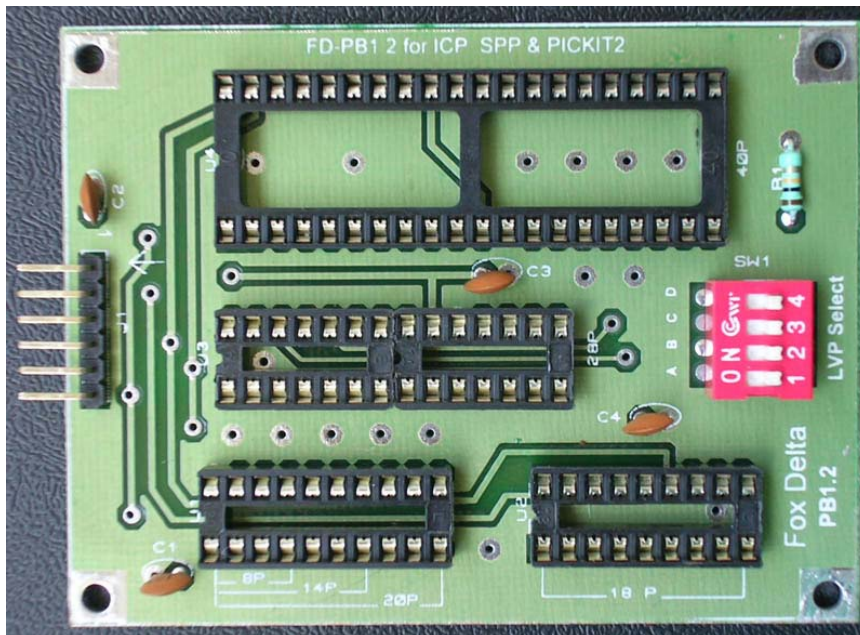

I hope this project would be useful to many

Dinesh Gajjar
7th April 09

For more information, please visit: <http://www.foxdelta.com>